

Composites Wire & Rope Sheave

From 1000 mm to 4000 mm up to 5000 kN

Umoe Advanced Composites is offering the new generation composite wire & rope sheave for use in heavy lifting system.

Introduction

The light weight carbon / glass fibre composite material offers a 50% weight saving compared with equivalent steel sheave and up to 60% reduction of the moment of inertia.

Maintenance costs are reduced as composites do not corrode.

An extensive test programme has been performed in order to qualify the product according to DNV offshore standard OS-C501. The sheave concept is pending type approved by DNV.

General benefits

- 50 % less weight compared to a corresponding steel sheave
- 60% less moment of inertia
- Corrosion resistant
- Excellent fatigue properties

Application specific benefits

- More lifting capacity on a crane
- Larger sheaves for same weight reduces bending fatigue on rope
- Less energy stored in rotation in a sheave block
- Reduces wear on wire due to increased responsiveness to accelerations

Customizable groove material

- Surface hardness
- Corrosion resistance
- Friction

Groove material examples:

- Hardened steel
- Stainless steel
- Duplex steel
- Nylatron
- Fiber reinforced thermoplastic



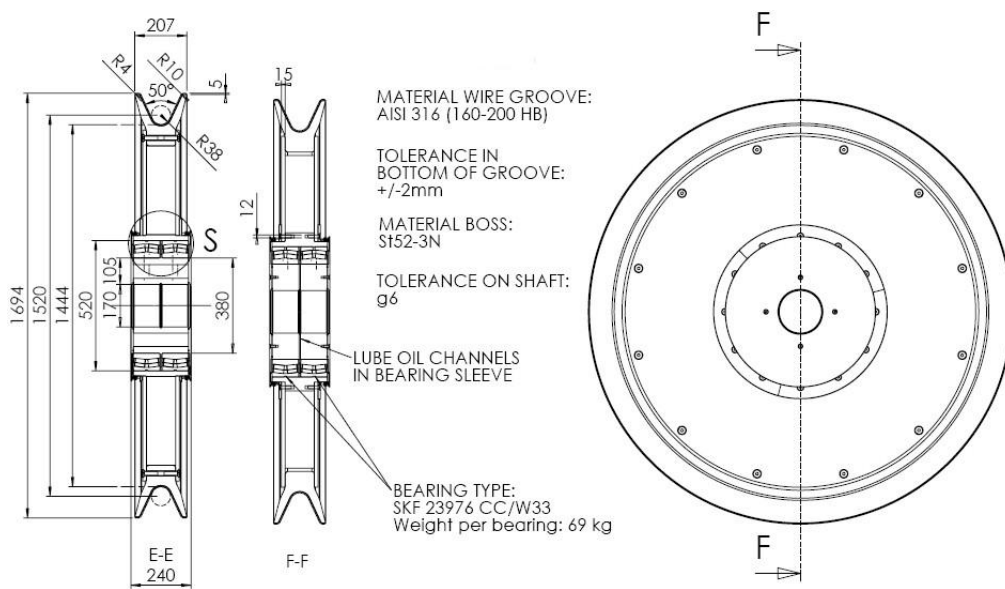

Example drawing of composite wire sheave with stainless steel groove liner

Diameter \ material	Composite	Steel	Nylatron
< 1,1m		X	X
1,1 m	X	X	X
1,6 m	X	X	
2,4 m	X		
>2,4 m	X		

Table showing our basic product range of sheaves and the types of materials they are offered in

Wire d (in)	Wire d (mm)	Bearing load (ton)	Sheave D (mm)
1 1/2	38	76	950
1 5/8	42	88	1050
1 3/4	45	102	1125
1 7/8	48	116	1200
2	52	131	1300
2 1/8	54	147	1350
2 1/4	58	164	1450
2 3/8	60	183	1500
2 1/2	64	200	1600
2 5/8	67	220	1675
2 3/4	71	240	1775
2 7/8	74	261	1850
3	77	283	1925
3 1/8	80	305	2000
3 1/4	83	328	2075
3 3/8	87	352	2175
3 1/2	90	375	2250
3 3/4	96	426	2400
4	103	479	2575

Table showing approximate wire and sheave diameters and load. D/d ratio is 25 but can be customized.

Specifications and dimensions given in this leaflet represents the state of engineering at the time of printing. Modification may take place and materials specified may be replaced without prior notice.

Umoe Advanced Composites AS
 Gismerøya, Mandal, Norway
 Tel: 38 27 92 00 – Fax 38 26 03 88
 e-mail: sales@uac.no,
 web: www.uac.no

